

RESOLUTION AND RECOVERY OF LARGE DNA FRAGMENTS

This section describes the application of agarose gel electrophoresis to both analytical and preparative separation of DNA fragments. Standard agarose gels separate DNA fragments from ~0.5 to 25 kb, whereas pulsed-field agarose gels resolve molecules from ~10 to >2000 kb. Descriptions of standard and pulsed-field agarose gel electrophoresis as well as parameters affecting resolution of large DNA fragments are presented in *UNITS 2.5A* and *2.5B*. Three different protocols that employ agarose gels to prepare DNA fragments are described in *UNIT 2.6*. A general description of gels as electric circuits can be found in the introduction to this chapter.

Agarose Gel Electrophoresis

UNIT 2.5A

Agarose gel electrophoresis is a simple and highly effective method for separating, identifying, and purifying 0.5- to 25-kb DNA fragments (see *UNIT 2.5B* for larger fragments). The protocol can be divided into three stages: (1) a gel is prepared with an agarose concentration appropriate for the size of DNA fragments to be separated; (2) the DNA samples are loaded into the sample wells and the gel is run at a voltage and for a time period that will achieve optimal separation; and (3) the gel is stained or, if ethidium bromide has been incorporated into the gel and electrophoresis buffer, visualized directly upon illumination with UV light.

RESOLUTION OF DNA FRAGMENTS ON STANDARD AGAROSE GELS

BASIC PROTOCOL

Materials

- Electrophoresis buffer (TAE or TBE; *APPENDIX 2*)
- Ethidium bromide solution (see recipe)
- Electrophoresis-grade agarose
- 10× loading buffer (see recipe)
- DNA molecular weight markers (see Fig. 2.5A.3)

- 55°C water bath
- Horizontal gel electrophoresis apparatus
- Gel casting platform
- Gel combs (slot formers)
- DC power supply

Preparing the gel

1. Prepare an adequate volume of electrophoresis buffer (TAE or TBE; see Critical Parameters, Electrophoresis buffers) to fill the electrophoresis tank and prepare the gel.

To facilitate visualization of DNA fragments during the run, ethidium bromide solution can be added to the electrophoresis buffer to a final concentration of 0.5 µg/ml. If buffer is prepared for the electrophoresis tank and the gel separately, be sure to bring both to an identical concentration of ethidium bromide.

CAUTION: *Ethidium bromide is a mutagen and potential carcinogen. Gloves should be worn and care should be taken when handling ethidium bromide solutions.*

2. Add the desired amount of electrophoresis-grade agarose to a volume of electrophoresis buffer sufficient for constructing the gel (see Table 2.5A.1). Melt the agarose in

Preparation and Analysis of DNA

2.5A.1

Contributed by Daniel Voytas

Current Protocols in Molecular Biology (2000) 2.5A.1-2.5A.9

Copyright © 2000 by John Wiley & Sons, Inc.

Table 2.5A.1 Appropriate Agarose Concentrations for Separating DNA Fragments of Various Sizes

Agarose (%)	Effective range of resolution of linear DNA fragments (kb)
0.5	30 to 1
0.7	12 to 0.8
1.0	10 to 0.5
1.2	7 to 0.4
1.5	3 to 0.2

a microwave oven or autoclave and swirl to ensure even mixing. Gels typically contain 0.8 to 1.5% agarose (see Critical Parameters, Agarose Concentration).

Melted agarose should be cooled to 55°C in a water bath before pouring onto the gel platform. This prevents warping of the gel apparatus. Gels are typically poured between 0.5 and 1 cm thick. Remember to keep in mind that the volume of the sample wells will be determined by both the thickness of the gel and the size of the gel comb.

3. Seal the gel casting platform if it is open at the ends. Pour in the melted agarose and insert the gel comb, making sure that no bubbles are trapped underneath the combs and all bubbles on the surface of the agarose are removed before the gel sets.

Most gel platforms are sealed by taping the open ends with adhesive tape. As an added measure to prevent leakage, hot agarose can be applied with a Pasteur pipet to the joints and edges of the gel platform and allowed to harden.

Loading and running the gel

4. After the gel has hardened, remove the tape from the open ends of the gel platform and withdraw the gel comb, taking care not to tear the sample wells.

Most gel platforms are designed so that 0.5 to 1 mm of agarose remains between the bottom of the comb and the base of the gel platform. This is usually sufficient to ensure that the sample wells are completely sealed and to prevent tearing of the agarose upon removal of the comb. Low percentage gels and gels made from low gelling/melting temperature agarose should be cooled at 4°C to gain extra rigidity and prevent tearing.

5. Place the gel casting platform containing the set gel in the electrophoresis tank. Add sufficient electrophoresis buffer to cover the gel to a depth of about 1 mm (or just until the tops of the wells are submerged). Make sure no air pockets are trapped within the wells.
6. DNA samples should be prepared in a volume that will not overflow the gel wells by addition of the appropriate amount of 10× loading buffer. Samples are typically loaded into the wells with a pipettor or micropipet. Care should be taken to prevent mixing of the samples between wells.

Be sure to include appropriate DNA molecular weight markers (see Fig. 2.5.3).

7. Be sure that the leads are attached so that the DNA will migrate into the gel toward the anode or positive lead. Set the voltage to the desired level, typically 1 to 10 V/cm of gel, to begin electrophoresis. The progress of the separation can be monitored by the migration of the dyes in the loading buffer.

CAUTION: To prevent electrical shocks, the gel apparatus should always be covered and kept away from heavily used work spaces.

- Turn off the power supply when the bromphenol blue dye from the loading buffer has migrated a distance judged sufficient for separation of the DNA fragments. If ethidium bromide has been incorporated into the gel, the DNA can be visualized by placing on a UV light source and can be photographed directly (see Support Protocol 2).

Gels that have been run in the absence of ethidium bromide can be stained by covering the gel in a dilute solution of ethidium bromide (0.5 $\mu\text{g}/\text{ml}$ in water) and gently agitating for 10 to 30 min. If necessary, gels can be destained by shaking in water for an additional 30 min. This serves to remove excess ethidium bromide which causes background fluorescence and makes visualization of small quantities of DNA difficult.

MINIGELS AND MIDIGELS

Small gels—minigels and midigels—can generally be run faster than larger gels and are often employed to expedite analytical applications. Because they use narrower wells and thinner gels, minigels and midigels also require smaller amounts of DNA for visualization of the separated fragments. Aside from a scaling down of buffer and gel volumes, the protocol for running minigels or midigels is similar to that described above for larger gels. Similarly, the parameters affecting the mobility of DNA fragments, discussed below, are the same for both large and small gels.

A number of manufacturers offer smaller versions of their large electrophoresis models. An important feature to consider when selecting a mini- or midigel apparatus is the volume of buffer held by the gel tank. As smaller gels are typically run at high voltages (>10 V/cm), electrophoresis buffers are quickly exhausted, and it is therefore advantageous to choose a gel apparatus with a relatively large buffer reservoir. Minigel boxes can also be easily constructed from a few simple materials (Maniatis et al., 1982). A small (e.g., 15 cm long \times 8 cm wide \times 4 cm high) plastic box can be equipped with male connectors and platinum wire electrodes at both ends to serve as a minimal gel tank (see Fig. 2.5A.1).

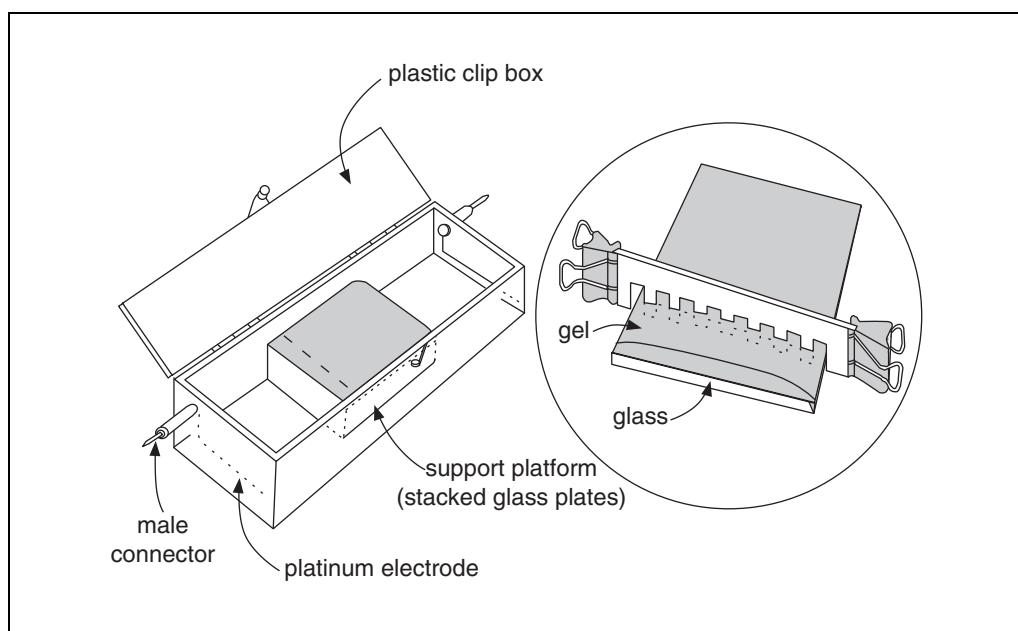

Figure 2.5A.1 Minigel apparatus.

SUPPORT PROTOCOL 1

Preparation and Analysis of DNA

2.5A.3

Although trays for casting small gels are commercially available, gels can also be poured onto glass lantern slides or other small supports without side walls. Such gels are held on the support simply by surface tension. After pouring the gel (e.g., 10 ml for a 5 cm × 8 cm gel), the comb is placed directly onto the support and held up by metal paper-binding clamps placed to the side.

Since there is no agarose at the bottom of such wells, extra care must be taken to prevent separation of the gel from the support when removing the comb.

PHOTOGRAPHY OF DNA IN AGAROSE GELS

DNA can be photographed in agarose gels stained with ethidium bromide by illumination with UV light ($>2500 \mu\text{W}/\text{cm}^2$). A UV transilluminator is typically used for this purpose, and commercial models are available designed specifically for DNA visualization and photography (e.g., UVP, Bio-Rad, Stratagene).

CAUTION: UV light is damaging to eyes and exposed skin. Protective eyewear should be worn at all times while using a UV light source.

The traditional means for photographing agarose gels uses a bellows-type camera equipped with a Polaroid film holder. An orange filter (Kodak Wratten #23A) is required to achieve a desirable image of light transmitted by fluorescing DNA. Polaroid type 667 film (ASA 3000) offers ideal sensitivity, allowing as little as several nanograms of DNA to be detected on film after making adjustments of exposure time. Gel photography systems can be set up by purchasing and assembling the individual components (e.g., camera, film holder, filters, and UV transilluminator). Alternatively, complete photography systems are commercially available (Bio-Rad, UVP).

A major disadvantage of traditional photography is the high cost of film. This can have a significant impact on a laboratory budget, particularly if large numbers of gels are processed on a routine basis. Because of this, traditional photography systems have been largely replaced with video imaging systems (e.g., Alpha Innotech Corp., Bio-Rad, Stratagene, and UVP; also see *UNIT 10.5*). Such systems use a CCD camera to capture the gel image and a video monitor to adjust focus and exposure time. A thermal printer generates inexpensive prints suitable for data documentation. A second advantage of imaging systems over traditional photography is that many systems come with video-processing computers and analysis software. This enables the degree of DNA fluorescence to be quantified (and thereby the relative amount of nucleic acid), and images can be stored for documentation and publication. Although the commercially available imaging systems are convenient, they can also be assembled on a less costly basis by purchasing the individual components and using public domain or commercially available software (Griess et al., 1995; Harriman and Wabl, 1995; Sutherland et al., 1987).

REAGENTS AND SOLUTIONS

Agarose gel

Gels typically contain ~1% agarose in 1× TAE or TBE (see *APPENDIX 2* for recipes; see Critical Parameters for choice of buffer). Electrophoresis-grade agarose powder is added to 1× gel buffer and melted by boiling for several minutes. Be sure all agarose particles are completely melted. To facilitate visualization of DNA fragments during the run, ethidium bromide can be added to 0.5 $\mu\text{g}/\text{ml}$ in the gel.

Ethidium bromide solution

1000× stock solution, 0.5 mg/ml:

50 mg ethidium bromide

100 ml H₂O

Working solution, 0.5 μg/ml:

Dilute stock 1:1000 for gels or stain solution

Protect from light.

10× loading buffer

20% Ficoll 400

0.1 M disodium EDTA, pH 8 (*APPENDIX 2*)

1.0% sodium dodecyl sulfate

0.25% bromphenol blue

0.25% xylene cyanol (optional; runs ~50% as fast as bromphenol blue and can interfere with visualization of bands of moderate molecular weight, but can be helpful for monitoring very long runs)

COMMENTARY

Background Information

Virtually all scientific investigations involving nucleic acids use agarose gel electrophoresis as a fundamental tool. Two papers that offer detailed descriptions of this technique and its practical use for DNA analysis are McDonnell et al. (1977) and Southern (1979).

Voltage applied at the ends of an agarose gel generates an electric field with a strength defined by the length of the gel and the potential difference at the ends (V/cm). DNA molecules exposed to this electric field migrate toward the anode due to the negatively charged phosphates along the DNA backbone. The migration velocity is limited by the frictional force imposed by the gel matrix. While charge and/or size can affect the rate at which macromolecules will pass through a gel, the charge to mass ratio is the same for DNA molecules of different lengths. It is the size of the DNA, therefore, that determines the rate at which it passes through the gel, thereby allowing an effective separation of DNA fragment-length mixtures by electrophoresis.

Critical Parameters

While agarose gel electrophoresis is straightforward and easy to perform, several factors should be considered before undertaking an electrophoretic separation. Parameters affecting the mobility of the DNA (i.e., applied voltage and agarose concentration) should be chosen for optimal resolution of the desired DNA fragment(s). The protocol should be designed such that the progress of the electrophoretic separation can be monitored and the

results accurately interpreted. This includes using such tools as tracking dyes and molecular weight markers.

Parameters affecting the migration of DNA through agarose gels

Agarose concentration. Molecules of linear, duplex DNA (form III) travel through gel matrices at a rate that is inversely proportional to the log₁₀ of their molecular weight (Helling et al., 1974). The molecular weight of a fragment of interest can therefore be determined by comparing its mobility to the mobility of DNA standards of known molecular weight. This is the most valuable feature of agarose gel electrophoresis, as it provides a reproducible and accurate means of characterizing DNA fragments by size.

Agarose concentration plays an important role in electrophoretic separations, as it determines the size range of DNA molecules that can be adequately resolved. Figure 2.5A.2A shows the effects of agarose concentration on mobility of fragments of different molecular weights. For most analyses, concentrations of 0.5% to 1.0% agarose are used to separate 0.5- to 30-kb fragments. However, low agarose concentrations (0.3 to 0.5%) are used to separate large DNA fragments (20 to 60 kb), and high agarose concentrations (1 to 1.5%) can resolve small DNA fragments (0.2 to 0.5 kb). See also Table 2.5A.1.

Applied voltage. In general, DNA fragments travel through agarose at a rate that is proportional to the applied voltage. With increasing voltages, however, large DNA molecules mi-

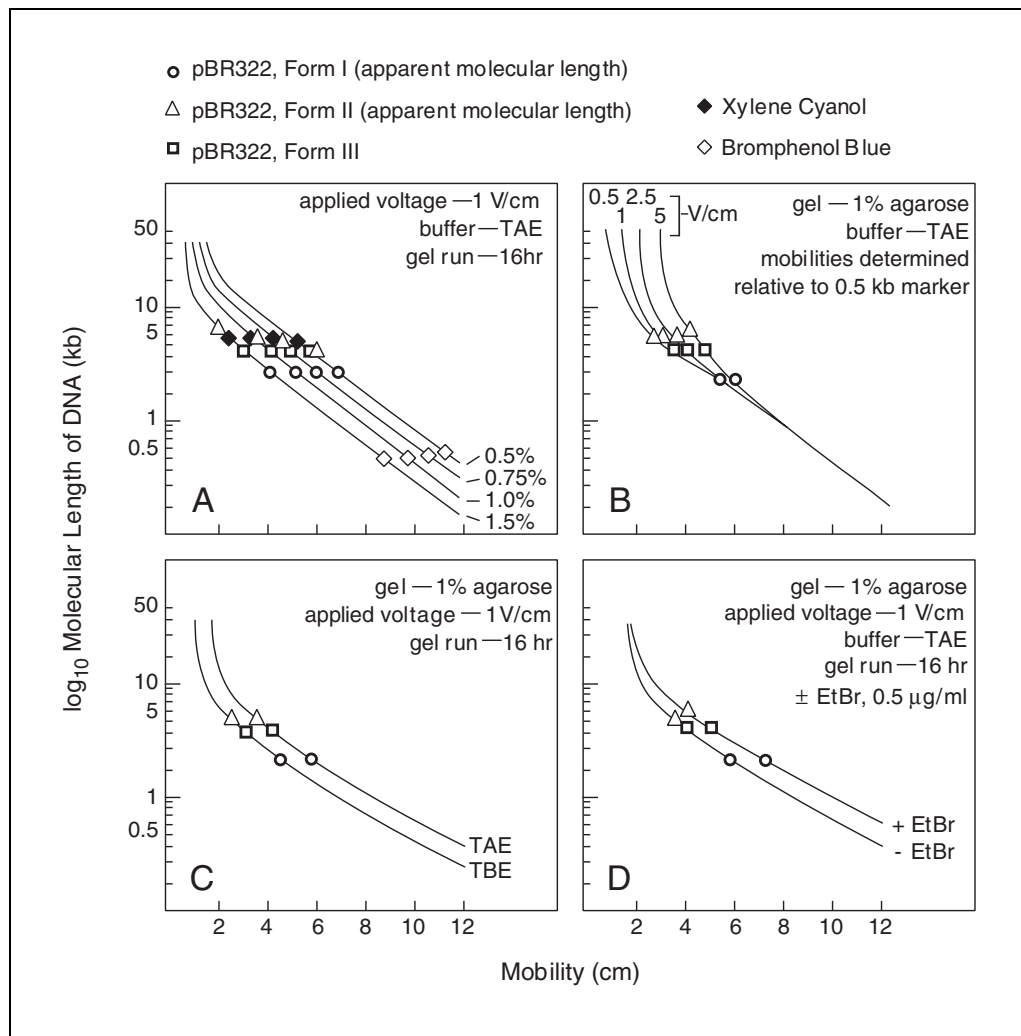

Figure 2.5A.2 Effect of (A) agarose concentration, (B) applied voltage, (C) electrophoresis buffer, and (D) ethidium bromide on migration of DNA through agarose gels.

grate at a rate proportionately faster than small DNA molecules. Consequently, higher voltages are significantly less effective in resolving large DNA fragments, as shown in Figure 2.5A.2B. For separating large DNA molecules, it is best to run gels at both low agarose concentrations and low applied voltages (~1 V/cm, 0.5% agarose).

Electrophoresis buffers. The two most widely used electrophoresis buffers are Tris/acetate (TAE) and Tris/borate (TBE). While these buffers have slightly different effects on DNA mobility (Figure 2.5A.2C), the predominant factor that should be considered in choosing between the two is their relative buffering capacity. Tris/acetate is the most commonly used buffer despite the fact that it is more easily exhausted during extended or high-voltage electrophoresis. Tris/borate has a significantly greater buffering capacity, but should be

avoided for purification of DNA from gels (see gel purification protocols).

DNA conformation. Closed circular (form I), nicked circular (form II), and linear duplex (form III) DNA of the same molecular weight migrate at different rates through agarose gels (Thorne, 1967). In the absence of ethidium bromide, closed circular supercoiled DNAs such as plasmids migrate faster than their linear counterpart DNAs (Fig. 2.5A.2D). Supercoiling essentially winds the molecules up, giving them a smaller hydrodynamic radius and allowing them to pass more readily through the gel matrix. Nicked or relaxed circular molecules that have lost all of their superhelicity migrate appreciably slower than either supercoils or linear molecules (Fig. 2.5A.2D; Johnson and Grossman, 1977).

The intercalating dye (ethidium bromide) is commonly incorporated into the gel and run-

ning buffer. The dye reduces the mobility of linear duplexes (Fig. 2.5A.2D) and has a particularly pronounced effect on the mobility of closed circular DNA. Ethidium bromide changes the superhelical density of closed circular molecules by inducing positive supercoils. With increasing concentrations of ethidium bromide, negative supercoils are gradually removed, causing a concomitant decrease in the mobility of the DNA molecule. This occurs until a critical free-dye concentration is reached where no more superhelical turns remain (usually between 0.1 to 0.5 $\mu\text{g}/\text{ml}$). As still more ethidium bromide is bound, positive superhelical turns are generated which, like negative supercoils, cause an increase in the electrophoretic mobility of the molecules (i.e., Fig. 2.5A.2D). By running gels at different concentrations of ethidium bromide, therefore, form I DNAs can easily be distinguished from other topoisomers.

Monitoring and interpreting separations of DNA through agarose gels

The DNA sample. In choosing the amount of DNA to be loaded, the width of the well plus the depth of the gel and the number and size of DNA fragments should be considered. Between 5 and 200 ng of a single DNA fragment can be loaded into a 0.5-cm-wide \times 0.2-cm-deep sample well; 5 ng approaches the minimal amount of an individual DNA fragment that can be detected by ethidium bromide staining, and 200 ng approximates the most that can be resolved before overloading occurs (the trailing and smearing characteristic of overloading become more pronounced with DNA fragments above 10 kb). For samples of DNA containing several fragments, between 0.1 and 0.5 μg of DNA is typically loaded per 0.5 cm sample well. Up to 10 μg of DNA can be adequately resolved for samples containing numerous fragments of different sizes (e.g., restriction digests of genomic DNA).

Tracking dyes. The most common means of monitoring the progress of an electrophoretic separation is by following the migration of tracking dyes that are incorporated into the loading buffer. Two widely used dyes displaying different electrophoretic mobilities are bromphenol blue and xylene cyanol. Xylene cyanol typically migrates with DNA fragments around 5 kb (Fig. 2.5A.2A) and bromphenol blue usually comigrates with DNA molecules around 0.5 kb (Fig. 2.5A.2A). Bromphenol Blue therefore provides an index of the mobility of the fastest fragments and is particularly

valuable in determining the length of the gel over which the separation of DNA has occurred. Xylene cyanol is useful for monitoring the progress of longer runs. Both dyes can interfere with the visualization of the fragments that comigrate with them.

Ethidium bromide. Ethidium bromide is commonly used for direct visualization of DNA in gels. The dye intercalates between the stacked bases of nucleic acids and fluoresces red-orange (560 nm) when illuminated with UV light (260 to 360 nm). This allows very small quantities of DNA to be detected (<5 ng) (Sharp et al., 1973).

Ethidium bromide is frequently added to the gel and running buffer prior to electrophoresis. While this has a slight effect on the mobility of the DNA (Fig. 2.5A.2D), it eliminates the need to stain the gel upon completion of the separation. An added advantage to running gels with ethidium bromide is that the mobility of the DNA can be monitored throughout the run until the desired separation is achieved.

Molecular weight markers. Among the samples loaded onto a gel, at least one lane should contain a series of DNA fragments of known sizes so that a standard curve can be constructed to allow the calculation of the sizes of unknown DNA fragments. The most commonly used molecular weight markers are restriction digests of phage λ DNA or, for smaller fragments, the plasmid pBR322. Figure 2.5A.3 shows the migration pattern and fragment sizes for restriction digests of λ DNA and pBR322 that are frequently used as molecular weight markers.

Aside from λ restriction fragments, many commercial preparations of molecular weight markers are also available. These products usually cover a wide range of DNA sizes, and some manufacturers also offer supercoiled (form I) markers for calculating plasmid sizes.

Troubleshooting

Common problems encountered in agarose gel electrophoresis are described below, along with several possible causes.

Poor resolution of DNA fragments. The most frequent cause of poor DNA resolution is improper choice of agarose concentration. Low percentage agarose gels should be used to resolve high-molecular-weight DNA fragments and high percentage gels for low-molecular-weight DNAs (see Table 2.5A.1). Fuzzy bands, encountered particularly with small DNA fragments, result from diffusion of the DNA through

the gel. This is especially true when gels are run for long periods of time at low voltages.

Band smearing. Trailing and smearing of DNA bands is most frequently observed with high-molecular-weight DNA fragments. This is often caused by overloading the DNA sample or running gels at high voltages. DNA samples loaded into torn sample wells will also cause extensive smearing, as the DNA will tend to run in the interface between the agarose and the gel support.

Melting of the gel. Melting of an agarose gel during an electrophoretic separation is a sign that either the electrophoresis buffer has been omitted in the preparation of the gel or has become exhausted during the course of the run. For high-voltage electrophoresis over long time periods, TBE should be used instead of TAE as it has a greater buffering capacity. Also, minigel and midigel boxes, which typically have small buffer reservoirs, tend to exhaust buffers more readily than larger gel boxes.

Anticipated Results

DNA fragments of ~0.5 to 25 kb are well resolved using the Basic Protocol. See following description of pulsed-field gel electrophoresis (UNIT 2.5B) for resolving molecules from ~10 to >2000 kb.

Time Considerations

Among the parameters that influence the length of time required to complete an electrophoretic separation, the one that has the greatest effect is the applied voltage. Most large agarose gels are run overnight (~16 hr) at voltages between 1 and 1.5 V/cm. While gels can be run much faster, particularly if the gel apparatus is cooled, resolution of larger DNA fragments is lost when higher voltages are used. Because the resolution required depends on the relative molecular weights of the fragments of interest, the time required for adequate separation is best determined empirically. As described above, this is most easily done by including ethidium bromide in the gel and then monitoring the progress of the run directly by visualization with UV light.

Mini- and midigels are typically run at high voltages relative to gel size (>10 V/cm) and are often completed in less than 1 hr. Two consequences of high-voltage runs should be kept in mind: First, as mentioned above, buffers become quickly exhausted and therefore TBE should be used, or gel tanks with large buffer capacities. Second, high voltages provide poor resolution of high-molecular-weight DNA fragments (see previous discussion). If large DNA fragments are to be separated, it may be advisable to use larger gels and/or lower applied voltages.

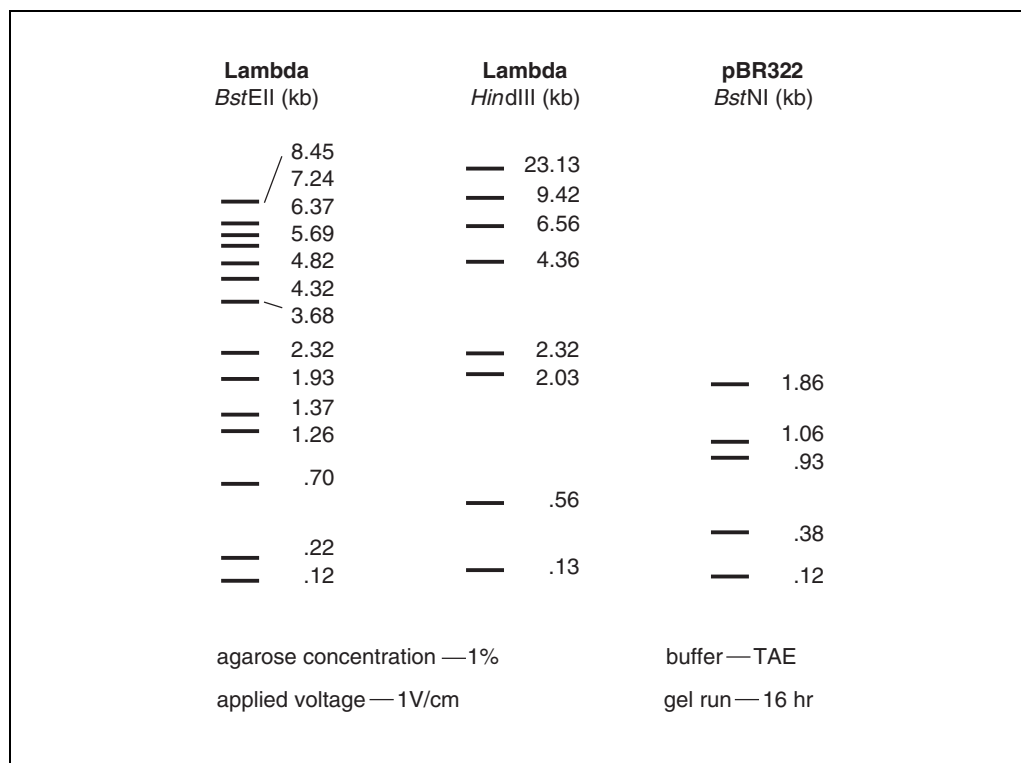

Figure 2.5A.3 Migration pattern and fragment sizes of common DNA molecular weight markers.

Literature Cited

- Griess, G.A., Louie, D., and Serwer, P. 1995. A desktop, low-cost video fluorometer for quantitation of macromolecules after gel electrophoresis. *Appl. Theor. Electrophor.* 4:175-177.
- Harriman, W.D., and Wabl, M. 1995. A video technique for the quantification of DNA in gels stained with ethidium bromide. *Anal. Biochem.* 228:336-342.
- Helling, R.B., Goodman, H.M., and Boyer, H.W. 1974. Analysis of R. *EcoRI* fragments of DNA from lambdoid bacteriophages and other viruses by agarose gel electrophoresis. *J. Virol.* 14:1235-1244.
- Johnson, P.H. and Grossman, L.I. 1977. Electrophoresis of DNA in agarose gels. Optimizing separations of conformational isomers of double- and single-stranded DNAs. *Biochemistry* 16:4217-4224.
- Maniatis, T., Fritsch, E.F., and Sambrook, J. 1982. *Molecular Cloning: A Laboratory Manual*. Cold Spring Harbor Laboratory, Cold Spring Harbor, NY.
- McDonnell, M.W., Simon, M.N., and Studier, F.W. 1977. Analysis of restriction fragments of T7 DNA and determination of molecular weights by electrophoresis in neutral and alkaline gels. *J. Mol. Biol.* 110:119-146.
- Sharp, P.A., Sugden, B., and Sambrook, J. 1973. Detection of two restriction endonuclease activities in *Haemophilus parainfluenzae* using analytical agarose. *Biochemistry* 12:3055-3063.
- Southern, E. 1979. Gel electrophoresis of restriction fragments. *Meth. Enzymol.* 68:152-176.
- Sutherland, J.C., Lin, B., Monteleone, D.C., Mugavero, J., Sutherland, B.M., and Trunk, J. 1987. Electronic imaging system for direct and rapid quantitation of fluorescence from electrophoretic gels: Application to ethidium bromide-stained DNA. *Anal. Biochem.* 163:446-457.
- Thorne, H.V. 1967. Electrophoretic characterization and fractionation of polyoma virus DNA. *J. Mol. Biol.* 24:203.

Contributed by Daniel Voytas
Iowa State University
Ames, Iowa